

# What do magnetic molecules teach about magnetism?

Jürgen Schnack

Department of Physics - University of Osnabrück  
<http://obelix.physik.uni-osnabrueck.de/~schnack/>

*Vortrag*  
TU Magdeburg, January 24th 2003

# Contents

- Magnetic molecules: composition and structure
- Interesting phenomena: LIESST, magnetization tunneling
- Model Hamiltonian: Heisenberg Hamiltonian & effective Hamiltonians
- General results: rings, bounds, rotational bands, magnetization jumps
- The giant Keplerate  $\{\text{Mo}_{72}\text{Fe}_{30}\}$
- The new Magdeburg-Osnabrück project
- Outlook

# What are magnetic molecules?

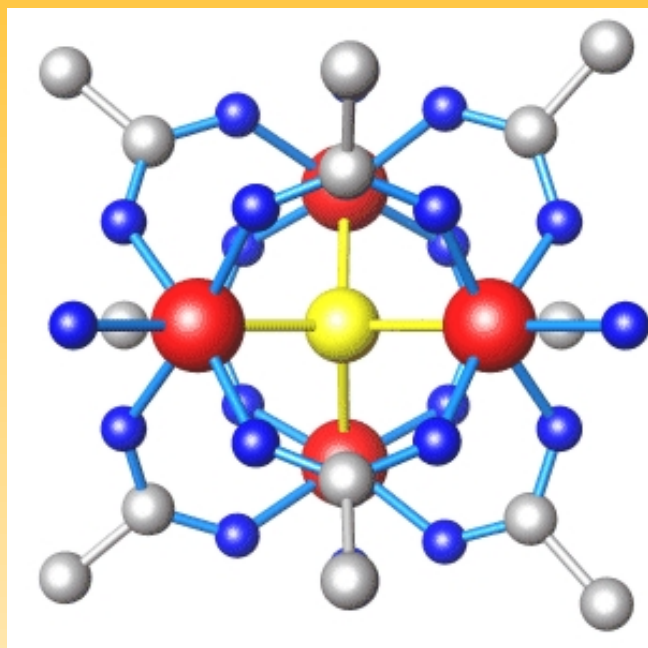

Cr<sub>4</sub>

- macro molecules (polyoxometalates etc.): consist of constituents like Hydrogen (H), Carbon (C), Oxygen (O), and diamagnetic ions (e.g. Mo) as well as paramagnetic ions like Iron (Fe), Chromium (Cr), Copper (Cu), Nickel (Ni) or Manganese (Mn);
- pure organic magnetic molecules: magnetic coupling between high spin units (e.g. free radicals);
- single spin quantum number  $1/2 \leq s \leq 7/2$ ;
- intermolecular interaction relatively small, therefore measurements reflect the thermal behaviour of a single molecule.

# Structure of magnetic molecules

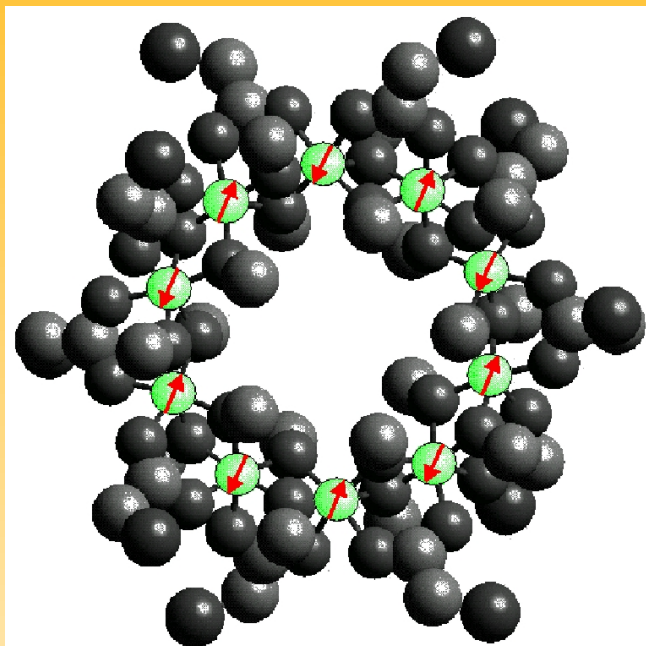

Fe<sub>10</sub>

- dimers (Fe<sub>2</sub>), tetrahedra (Cr<sub>4</sub>), cubes (Cr<sub>8</sub>);
- rings, especially iron rings (Fe<sub>6</sub>, Fe<sub>8</sub>, Fe<sub>10</sub>, ...);
- complex structures (Mn<sub>12</sub>) – drosophila of molecular magnetism;
- soccer balls, more precisely icosidodecahedra (Fe<sub>30</sub>) and other macro molecules;
- chain like and planar structures of interlinked magnetic molecules.

# Example of magnetic macro molecules

## {Mo<sub>72</sub>Fe<sub>30</sub>}

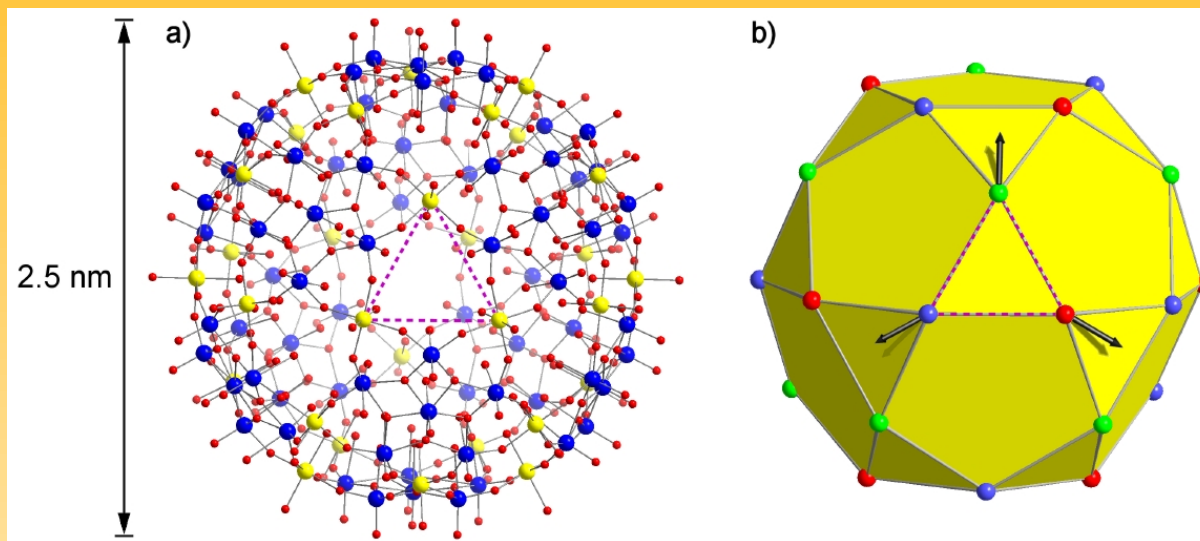

- structure of {Mo<sub>72</sub>Fe<sub>30</sub>}: Fe - yellow, Mo - blue, O - red,
- antiferromagnetic interaction mediated by O-Mo-O bridges (1).
- classical ground state of {Mo<sub>72</sub>Fe<sub>30</sub>}: three sublattice structure, coplanar spins (2);
- quantum mechanical ground state  $S = 0$  can only be approximated, dimension of Hilbert space  $(2s + 1)^N \approx 10^{23}$ .

(1) A. Müller *et al.*, Chem. Phys. Chem. **2**, 517 (2001) , (2) M. Axenovich and M. Luban, Phys. Rev. B **63**, 100407 (2001)

# Why study magnetic molecules?

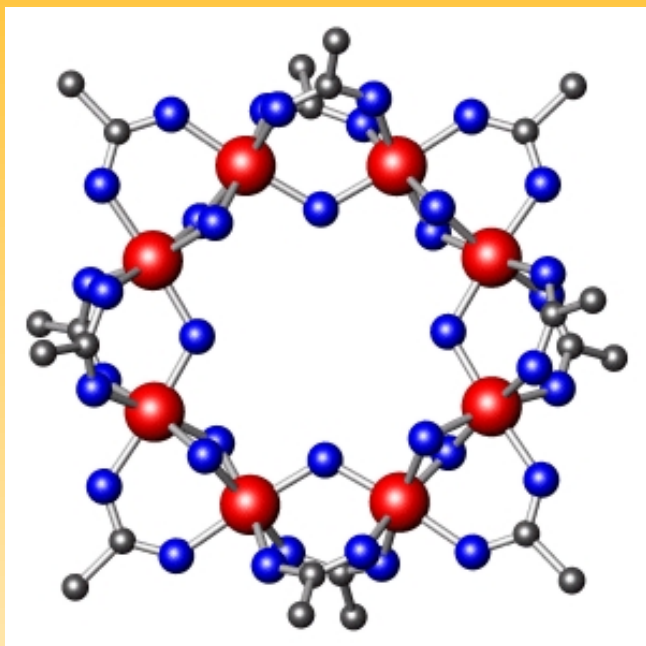

Cr<sub>8</sub>

- transition few-spin system  $\Rightarrow$  many-spin system, contribution to understanding of bulk magnetism;
- transition quantum spin system ( $s = 1/2$ )  $\Rightarrow$  classical spin system (Fe:  $s = 5/2$ , Gd:  $s = 7/2$ );
- easy to produce, single crystals with  $> 10^{17}$  identical molecules can be synthesized and practically completely characterized;
- speculative applications: magnetic storage devices, magnets in biological systems, light-induced nano switches, displays, catalysts, qubits for quantum computers.

# Light Induced Excited Spin State Trapping (LIESST)

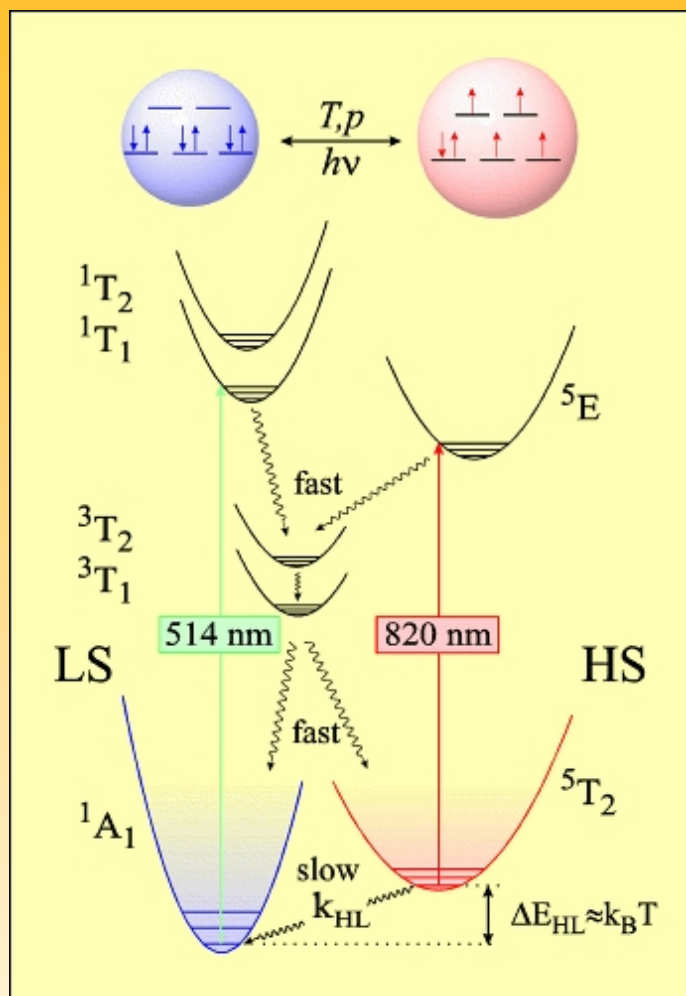

- magnetic molecules may serve as optical switches or displays;
- materials: spin crossover substances which show the LIESST effect;
- example: sixfold coordinated iron, spin-dependent radial harmonic potential;
- principle: reversible change in colour (and structure) when irradiated with laser light or when heated as well as cooled.

<http://ak-guetlich.chemie.uni-mainz.de/toss/liesst.shtml>

# Magnetic molecules as storage media?

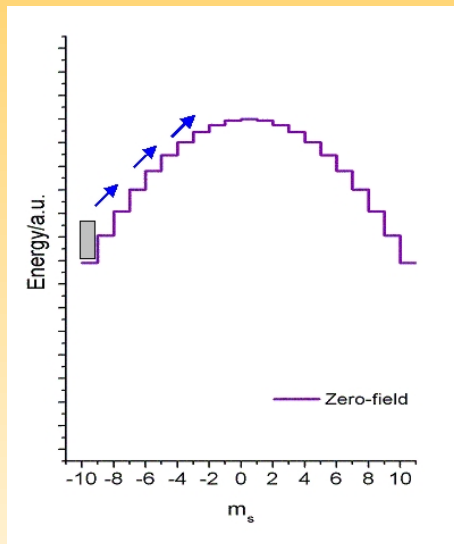
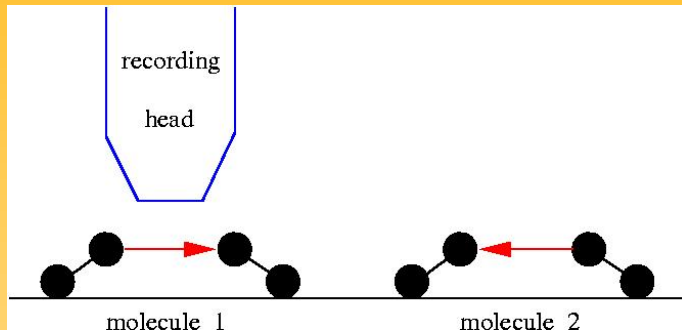

- Single Molecule Magnet (SMM): magnetic molecule with high ground state spin and hysteresis (usually due to large anisotropy);
- every molecule is a domain of its own; very weak intermolecular interactions; high density and nevertheless good separation of magnetic moments;
- high ground state spin possible, e.g.  $S = 10$  for  $Mn_{12}$ ;
- theoretically possible storage density: **40 Tbits per square inch**, today: 20 Gbits per square inch (IBM), 300GB per square inch (Fujitsu 05/2002)



# Magnetic molecules as storage media?

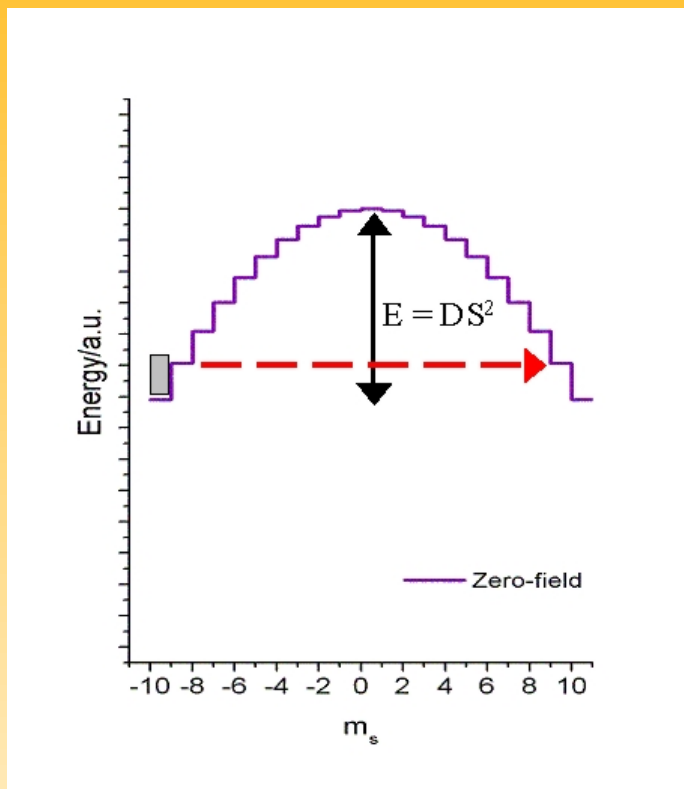

## Disadvantages:

- magnetization tunneling – stabilisation by appropriate substrate?  
Prof. Blügel, Osnabrück/Jülich,  
<http://www.flapw.de>
- often very small coupling ( $J \approx 10$  K), i.e. thermally unstable at room temperature;
- recording head must be very small and needs precise guide.

[http://www.people.man.ac.uk/~mbdssrew/winpeny\\_intro3.html](http://www.people.man.ac.uk/~mbdssrew/winpeny_intro3.html)

# Magnetization tunneling

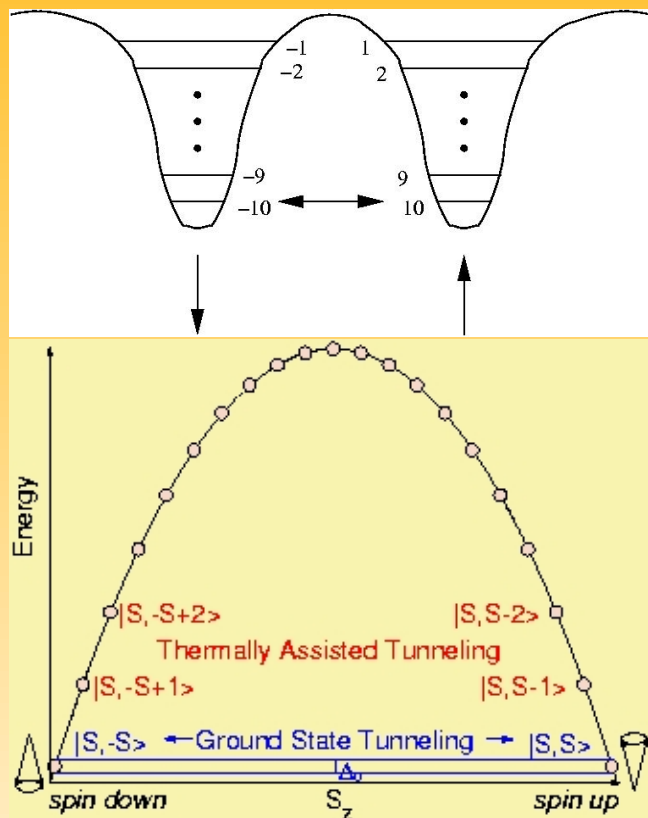

©Wolfgang Wernsdorfer, Grenoble

- for SMM like  $Mn_{12}$  (l.h.s.) an effective one-spin Hamiltonian can be used:

$$\tilde{H} = -D\tilde{S}_z^2 - D_4\tilde{S}_z^4 + \tilde{H}'$$

$$\tilde{H}' = g\mu_B H_x \tilde{S}_x$$

- tunneling rate depends on initial  $M$ :
  - $M = 10 \Rightarrow \omega \approx 10^{-45} \text{ Hz } (H_x = 100 \text{ G})$
  - $M = 2 \Rightarrow \omega \approx 10^5 \text{ Hz } (H_x = 100 \text{ G})$
- macroscopic magnetization tunneling possible;
- thermally activated tunneling observed.

## Model Hamiltonian – Heisenberg-Model

$$\underline{H} = - \sum_{i,j} J_{ij} \vec{s}(i) \cdot \vec{s}(j) - D \sum_i \left( \vec{e}(i) \cdot \vec{s}(i) \right)^2 + g \mu_B B \sum_i s_z(i)$$

Heisenberg
Anisotropy
Zeeman

The Heisenberg model including anisotropy, and dipol-dipol interaction if necessary, as well as a Zeeman term describes the magnetic spectrum of many molecules with high accuracy, although its derivation by means of *ab initio* calculations (DFT?) remains a challenge.

Since the dimension of Hilbert space equals  $(2s + 1)^N$  the Hamiltonian can be diagonalized completely for small molecules. For larger ones approximate methods are used.

# Spin rings I

Shift operator commutes with Heisenberg Hamiltonian  $[\underline{H}, \underline{T}] = 0$ :

$$\underline{T} |m_1, \dots, m_{N-1}, m_N\rangle = |m_N, m_1, \dots, m_{N-1}\rangle$$

$$\underline{H} |\phi_\nu\rangle = E_\nu |\phi_\nu\rangle, \quad \underline{T} |\phi_\nu\rangle = \exp\left\{-i\frac{2\pi k_\nu}{N}\right\} |\phi_\nu\rangle, \quad k_\nu = 0, \dots, N-1$$

Properties of the  $k$ -quantum number of the ground state are known for rings of even  $N$  (Marshall, Peierls, Lieb, Schultz, Mattis).

Numerical investigations revealed that the  $k$  quantum number fulfills certain rules for all spin rings, also those of odd  $N$ .

K. Bärwinkel, H.-J. Schmidt, and J. Schnack, J. Magn. Mater. **220**, 227 (2000);  
 J. Schnack, Phys. Rev. B **62**, 14855 (2000)

## Spin rings II

Numerical evidence from exact diagonalization:

1. ground state belongs to  $\mathcal{H}(S)$  with smallest possible  $S$ ;
2. ground state within a subspace of constant  $M$  has  $S = |M|$ ;
3. if  $N \cdot s$  is integer, then the ground state is non-degenerate;
4. if  $N \cdot s$  is half integer, then the ground state is fourfold degenerate;
5. if  $s$  is integer or  $N \cdot s$  even, then  $k = 0$ ;
6. if  $s$  is half integer and  $N \cdot s$  odd,  $k = N/2$ ;
7. If  $N \cdot s$  is half integer, then  $k = \lfloor (N + 1)/4 \rfloor$  and  $k = N - \lfloor (N + 1)/4 \rfloor$ ;  
 $\lfloor (N + 1)/4 \rfloor$  greatest integer less or equal to  $(N + 1)/4$ .

# Spin rings III

$S$	$N$										
	2	3	4	5	6	7	8	9	10		
$\frac{1}{2}$	1.5	0.5	1	0.747	0.934	0.816	0.913	0.844	0.903	$E_0/(NJ)$	
	1	4	1	4	1	4	1	4	1	deg	
	0	1/2	0	1/2	0	1/2	0	1/2	0	$S$	
	1	1, 2	0	1, 4	3	2, 5	0	2, 7	5	$k$	
1	4	2	3	2.612	2.872	2.735	2.834	2.773	2.819	$E_0/(NJ)$	
	1	1	1	1	1	1	1	1	1	deg	
	0	0	0	0	0	0	0	0	0	$S$	
	0	0	0	0	0	0	0	0	0	$k$	
$\frac{3}{2}$	7.5	3.5	6	4.973	5.798	5.338	5.732	5.477	5.704 <sup>††</sup>	$E_0/(NJ)$	
	1	4	1	4	1	4	1	4	1	deg	
	0	1/2	0	1/2	0	1/2	0	1/2	0	$S$	
	1	1, 2	0	1, 4	3	2, 5	0	2, 7	5	$k$	
2	12	6	10	8.456	9.722	9.045	9.630	9.263 <sup>††</sup>	9.590 <sup>††</sup>	$E_0/(NJ)$	
	1	1	1	1	1	1	1	1	1	deg	
	0	0	0	0	0	0	0	0	0	$S$	
	0	0	0	0	0	0	0	0	0	$k$	
$\frac{5}{2}$	17.5	8.5	15	12.434	14.645	13.451	14.528 <sup>†</sup>	13.848 <sup>††</sup>	14.475 <sup>††</sup>	$E_0/(NJ)$	
	1	4	1	4	1	4	1	4	1	deg	
	0	1/2	0	1/2	0	1/2	0	1/2	0	$S$	
	1	1, 2	0	1, 4	3	2, 5	0	2, 7	5	$k$	

# Bounds

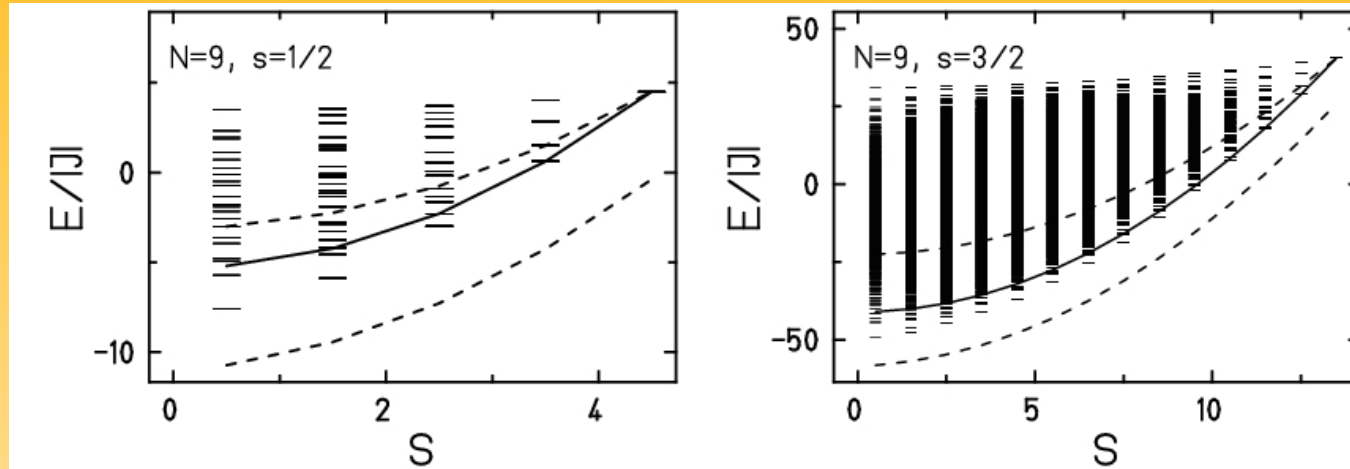

- confine minimal energies as function of  $M$  or  $S$ , improve bounds by Berezin and Lieb (1) and our first try (2);
- bounds must be obeyed by approximations like DMRG; (parabolic) bounds may serve as approximation of lowest (rotational) band.

(1) E. H. Lieb, Commun. Math. Phys. **31**, 327 (1973)  
 F. Berezin, Commun. Math. Phys. **40**, 153 (1975)  
 (2) H.-J. Schmidt, J. Schnack, and M. Luban, Europhys. Lett. **55**, 105 (2001)

## Make use of $n$ -partiteness for upper bounds

- $n$ -partiteness: graph of interactions can be mapped onto oriented cyclic graph with  $n$  vertices;
- e.g.: rings –  $N$ -partite, triangular lattice – 3-partite, square lattice – 4-partite, cubic lattice – 2-partite, kagomé lattice – 3-partite, but not 6-partite;
- transform  $\tilde{H}$  with generalized “Bloch” operator  $\tilde{U}$  (1);
- variational state:  $|\phi\rangle = C_M \tilde{U}(S^-)^a |\Omega\rangle$ ,  $|\Omega\rangle \equiv |s, s, s, \dots\rangle$  magnon vacuum.

$$E_{\min}(M) \leq \langle \phi | \tilde{H} | \phi \rangle = c|\Gamma|s^2 + \left(1 - \frac{c}{\delta}\right) \frac{\delta|\Gamma|}{N} \left( Ns^2 - \frac{2sa(2Ns - a)}{2Ns - 1} \right),$$

where  $c = -1$  in the case of even  $n$  (bipartite) and  $c = -\cos \frac{\pi}{n}$  for odd  $n$ .

(1) I. Affleck, E. H. Lieb, Lett. Math. Phys. **12** (1986) 57



# Bounds for the icosidodecahedron (1)

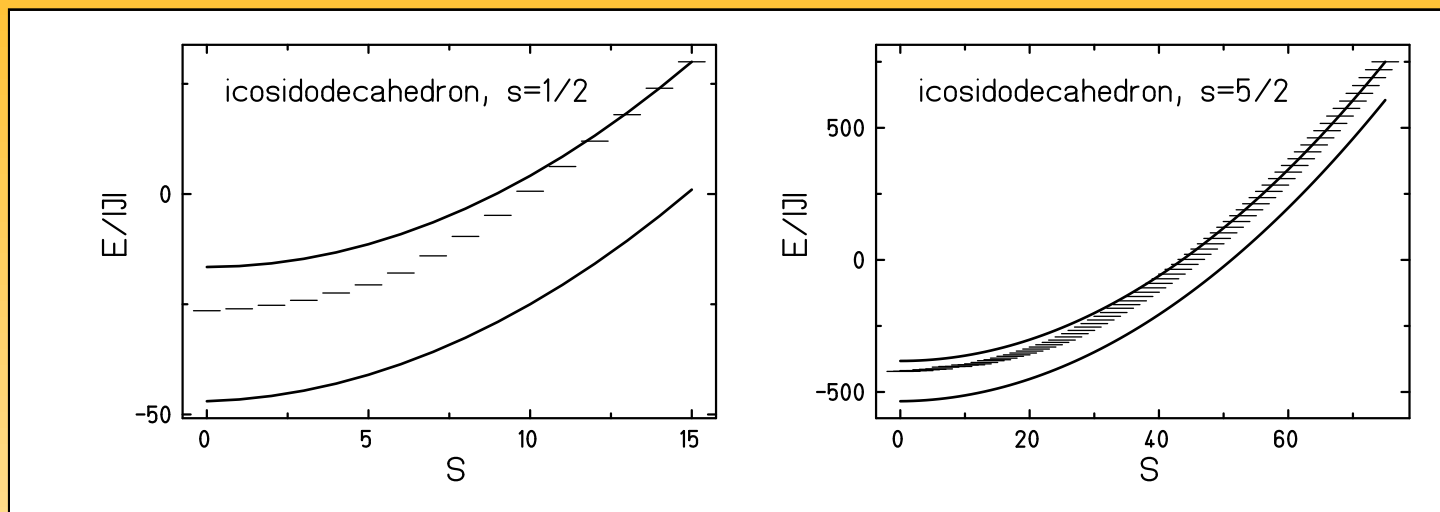

- minimal energies for the icosidodecahedron:  
 $s = 1/2$  from J. Richter (2),  $s = 5/2$  DMRG (3);
- upper bound rather close to true minimal energies, the better the larger  $s$ .

(1) K. Bärwinkel, H.-J. Schmidt, and J. Schnack, Eur. Phys. J. B (2002) submitted, cond-mat/0210458

(2) J. Schnack, H.-J. Schmidt, J. Richter, J. Schulenburg, Eur. Phys. J. B **24** (2001) 475

(3) M. Exler, J. Schnack, Phys. Rev. B (2002), submitted, cond-mat/0205068

# Lower bounds for $n$ -homogeneous Lieb-Mattis systems

$$\underline{H} = \sum_{\mu\nu} J_{\mu\nu} \underline{\vec{S}}_{\mu} \cdot \underline{\vec{S}}_{\nu}, \quad \sum_{b \in \mathcal{A}_{\mu}} J_{ab} = \begin{cases} j^{\text{in}} & \text{if } a \in \mathcal{A}_{\mu} \\ j^{\text{ex}} & \text{if } a \notin \mathcal{A}_{\mu} \end{cases}$$

- matrix  $\mathbb{J} \equiv (J_{\mu\nu})$  be symmetric and have constant row sums  $j$ ;
- $n$ -HLM systems: set of spin sites be divided into  $n$  disjoint subsets of equal size  $m$ ,  $\{1, \dots, N\} = \bigcup_{\nu=1}^n \mathcal{A}_{\nu}$ ;  
within each  $\mathcal{A}_{\nu}$ :  $J_{\mu\nu} \leq 0$ , but  $\geq 0$  between  $\mathcal{A}_{\nu}$  and  $\mathcal{A}_{\mu}$  for  $\nu \neq \mu$ ;
- smallest eigenvalue  $j_{\min}$  at least  $(n - 1)$ -times degenerate because of  $n$ -homogeneity,  $j_2$  is the remaining smallest eigenvalue;
- construction of a coupling matrix  $\tilde{\mathbb{J}}$  with eigenvalues  $j$  ( $1$ ),  $j_{\min}$  ( $n - 1$ ),  $j_2$  ( $N - n$ );
- $\mathbb{J} \geq \tilde{\mathbb{J}} \Rightarrow \underline{H} \geq \frac{j - j_{\min}}{N} S(S + 1) + N j_{\min} s(s + 1) + (N - n)(j_2 - j_{\min})s$  .

# Bounds for the triangular lattice

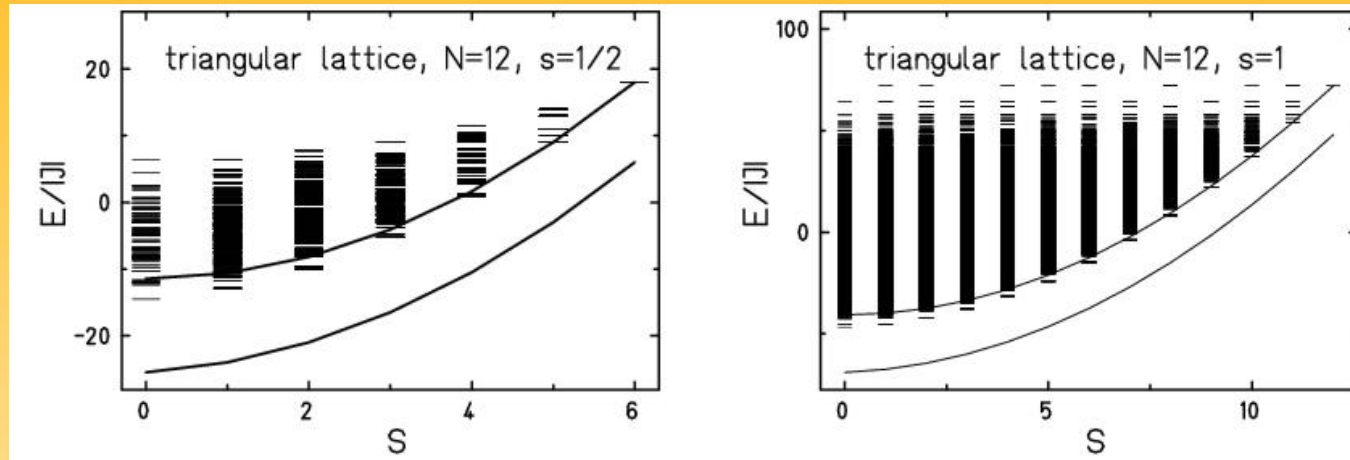

$$9S_c^2 - 3s^2 - 3s \leq \lim_{N \rightarrow \infty} \frac{E_{\min}(S)}{N} \leq 9S_c^2 - 3s^2 ,$$

where  $S_c = S/N$  running from 0 to  $s$ .

K. Bärwinkel, H.-J. Schmidt, and J. Schnack, Eur. Phys. J. B (2002) submitted, cond-mat/0210458

# Rotational bands

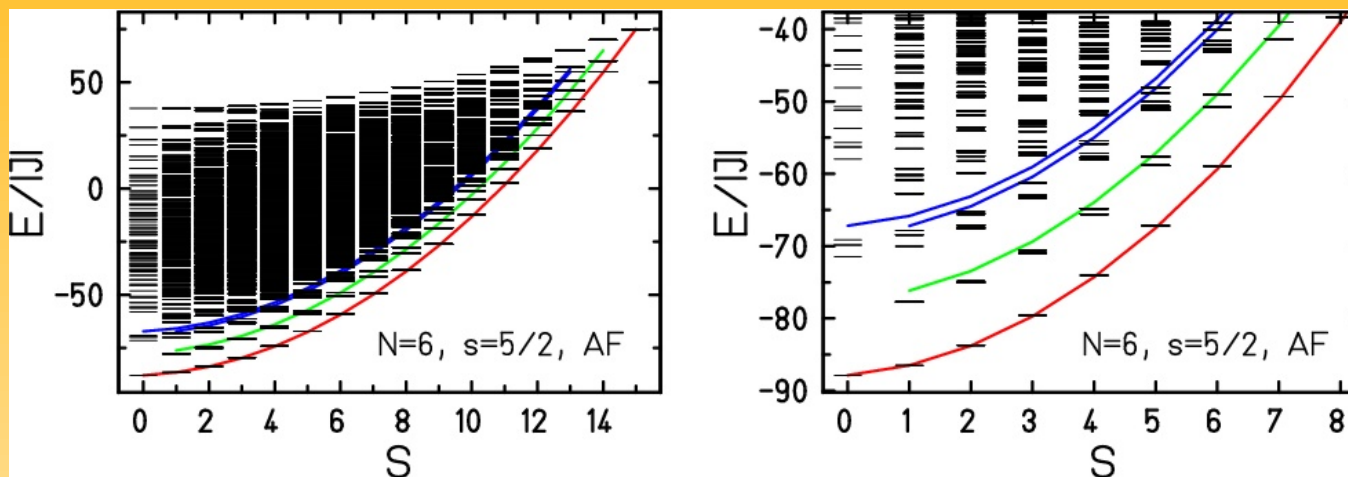

- very often minimal energies  $E_{min}(S)$  form a rotational band – Landé interval rule (1);
- most pronounced for bipartite systems (2), but also a good approximation for more general systems;
- sometimes low-lying spectrum is a sequence of rotational bands (3).

(1) A. Caneschi *et al.*, Chem. Eur. J. **2**, 1379 (1996), G. L. Abbati *et al.*, Inorg. Chim. Acta **297**, 291 (2000)

(2) J. Schnack and M. Luban, Phys. Rev. B **63**, 014418 (2001)

(3) O. Waldmann, Phys. Rev. B **65**, 024424 (2002)

# {Mo<sub>72</sub>Fe<sub>30</sub>} - rotational band hypothesis

$$\tilde{H} = -2J \sum_{(u < v)} \tilde{\vec{s}}(u) \cdot \tilde{\vec{s}}(v) \approx -\frac{DJ}{N} \left[ \tilde{S}^2 - \sum_{j=1}^{N_{SL}} \tilde{S}_j^2 \right] = \tilde{H}^{\text{eff}}$$

- Fe<sub>30</sub>:  $N_{SL} = 3$ ;  $S_A, S_B, S_C = 0, 1, \dots, 25$ ;  $S = 0, 1, \dots, 75$ ;
- $D = 6$  either from classical counterpart or symmetry considerations or properties of coupling matrix;

J. Schnack, M. Luban, R. Modler, Europhys. Lett. **56** 863 (2001)

H.-J. Schmidt, J. Schnack, and M. Luban, Europhys. Lett. **55**, 105 (2001)

# {Mo<sub>72</sub>Fe<sub>30</sub>} - magnetization

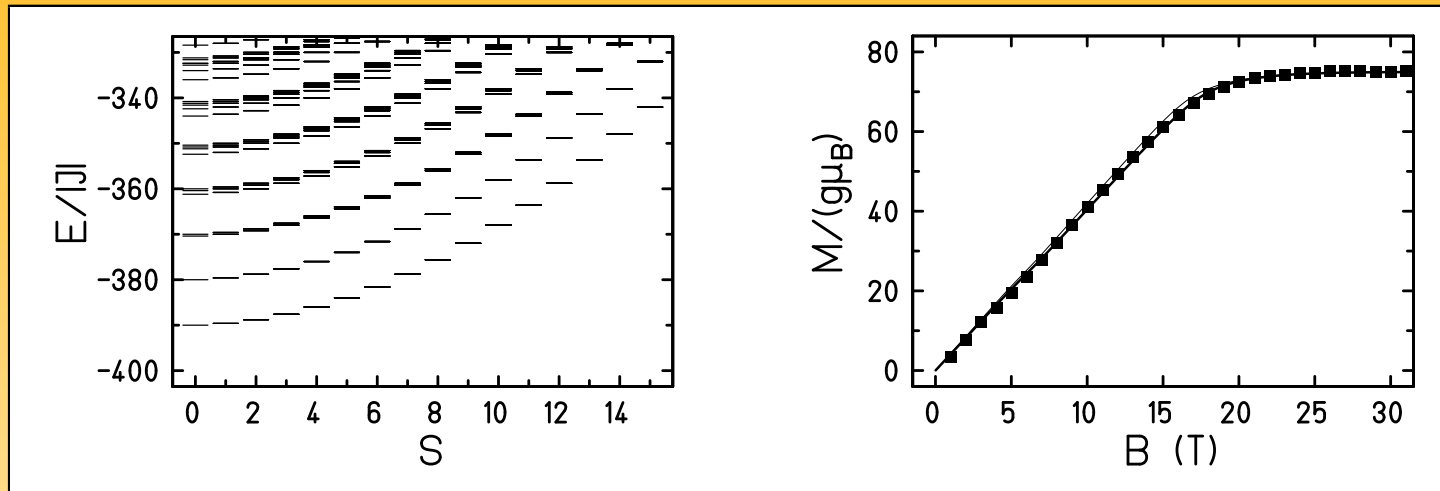

- sequence of rotational bands rather unrealistic for this frustrated system;
- nevertheless magnetization at  $T = 0.46$  K very well reproduced.

J. Schnack, M. Luban, R. Modler, *Europhys. Lett.* **56** 863 (2001) 863

A. Müller *et al.*, *Chem. Phys. Chem.* **2**, 517 (2001)

# {Mo<sub>72</sub>Fe<sub>30</sub>} - magnetization jump

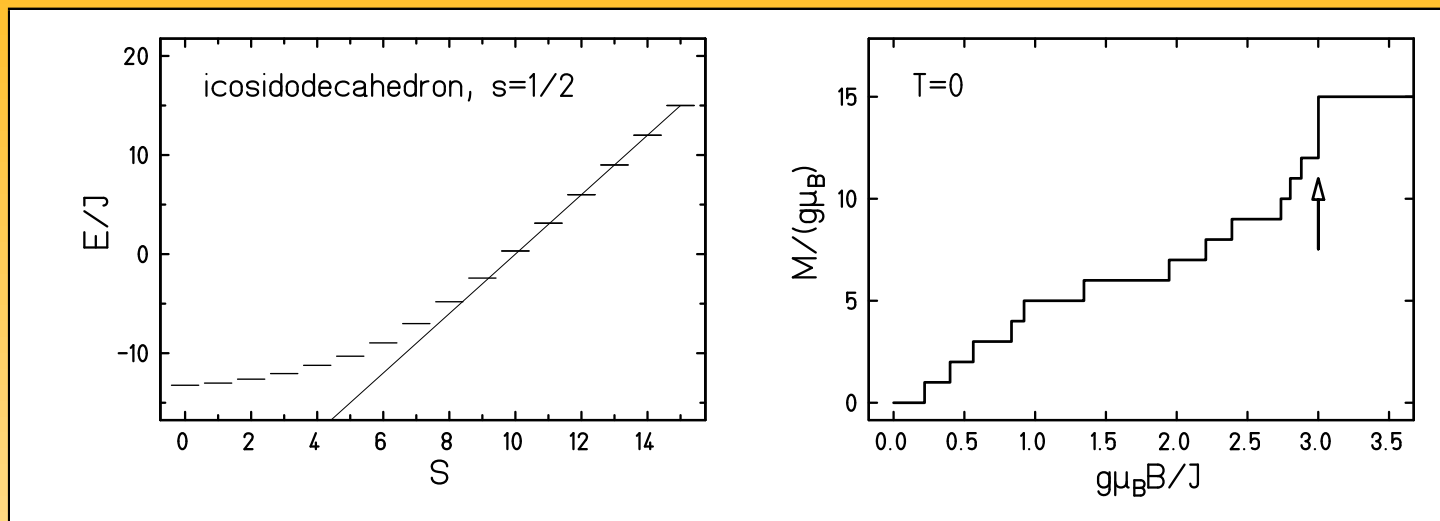

- $E_{\min}(S)$  linear in  $S$  for high  $S$  instead of being quadratic (1);
- for the Heisenberg model this property depends only on the structure but not on  $s$  (2);
- reason for magnetization jump: independent magnons (3);
- see talk of Johannes Richter.

(1) J. Schnack, H.-J. Schmidt, J. Richter, J. Schulenburg, Eur. Phys. J. B **24**, 475 (2001)

(2) H.-J. Schmidt, J. Phys. A: Math. Gen. **35**, 6545 (2002)

(3) J. Schulenburg *et al.*, Phys. Rev. Lett. **88**, 167207 (2002)

# {Mo<sub>72</sub>Fe<sub>30</sub>} - magnetization revisited

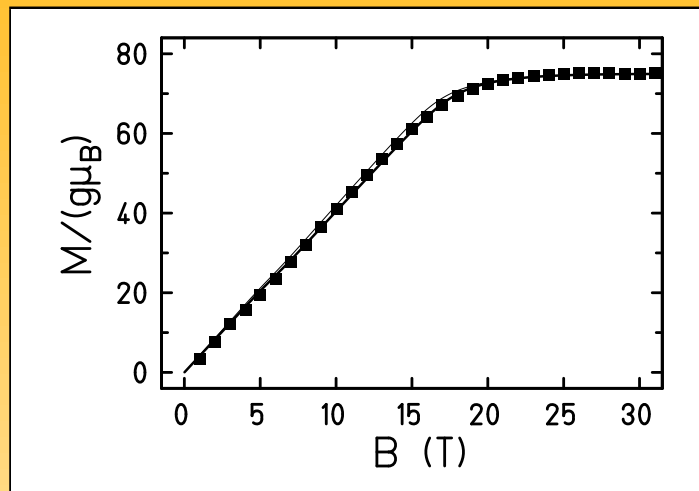

- magnetization at  $T = 0.46$  K, although very well reproduced, rather boring; since temperature already larger than low-lying gaps, one does not learn much about the detailed level structure;
- closer inspection of the data shows fine structure (!);
- data taken at the National High Magnetic Field Laboratory (NHMFL) at Los Alamos:  $\dot{B}(t = 0) \approx 20000$  T/s.



# Time-dependent magnetic fields

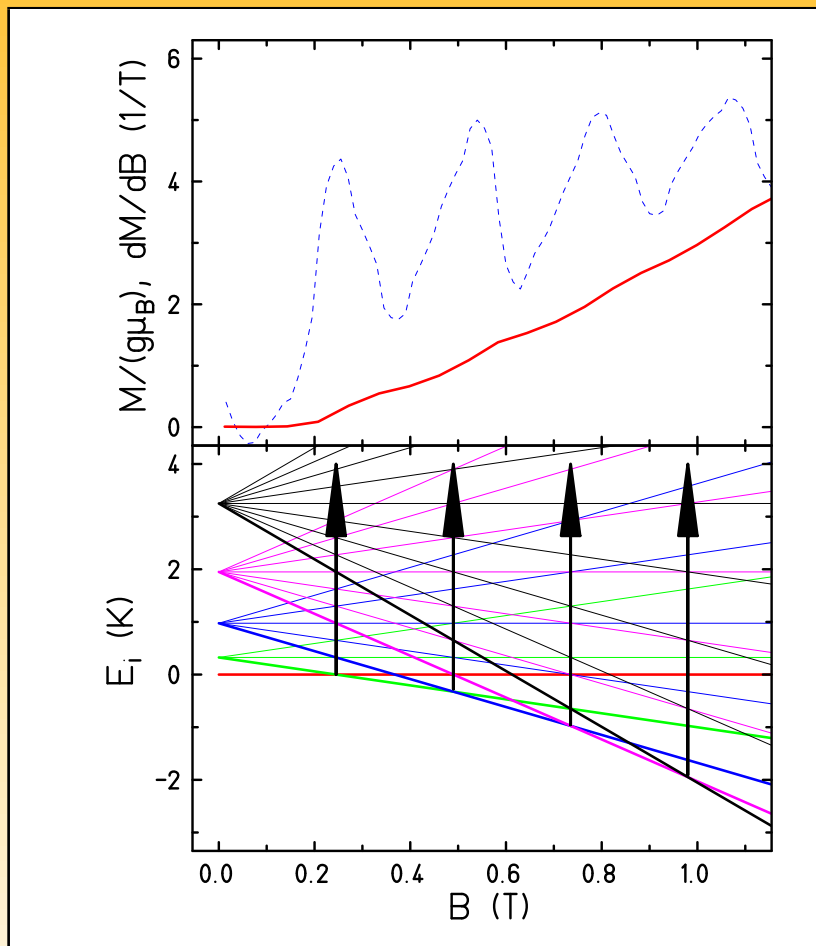

- magnetization tunneling at avoided level crossings  $\Rightarrow$  description via time-dependent Schrödinger equation or Landau-Zener formula;
- $\Rightarrow$  hysteresis effects;
- relaxation processes due to phonons  $\Rightarrow$  description with detailed balance;
- $\Rightarrow$  flattens hysteresis;
- measurements shows two things:
  - (1) time-dependent magnetic field valuable to detect level crossings even at higher temperatures;
  - (2) lowest rotational band predicts level crossings at almost correct positions.

# {Mo<sub>72</sub>Fe<sub>30</sub>} - lowest rotational band with DMRG

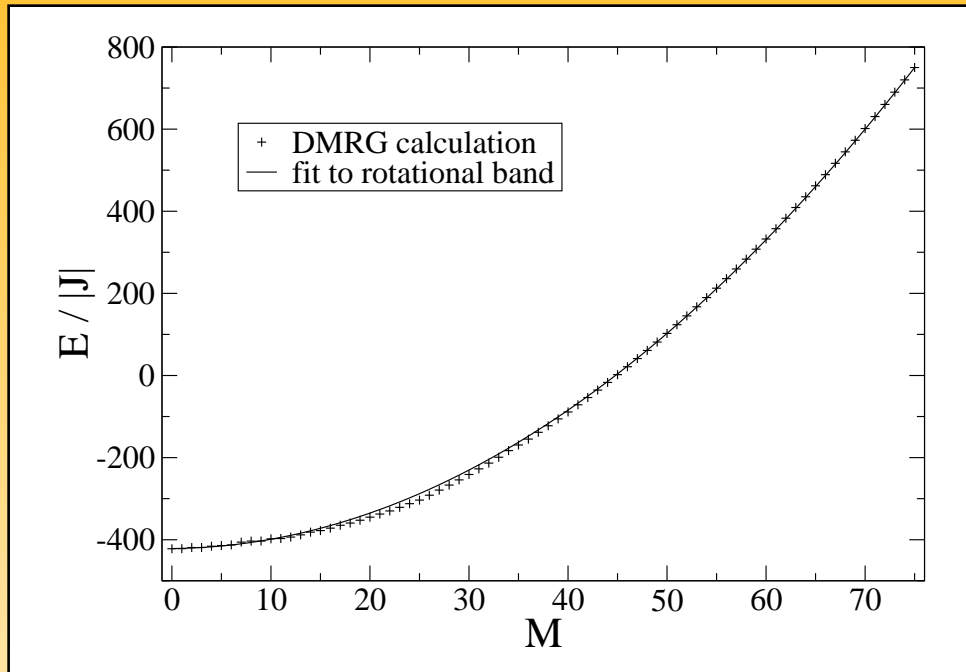

- lowest rotational band also confirmed by DMRG calculations;
- difficult to calculate since quasi two-dimensional and finite;
- accuracy tested with an icosidodecahedron of  $s = 1/2$ .

M. Exler, J. Schnack, Phys. Rev. B (2002), submitted, cond-mat/0205068

# The new Magdeburg-Osnabrück project

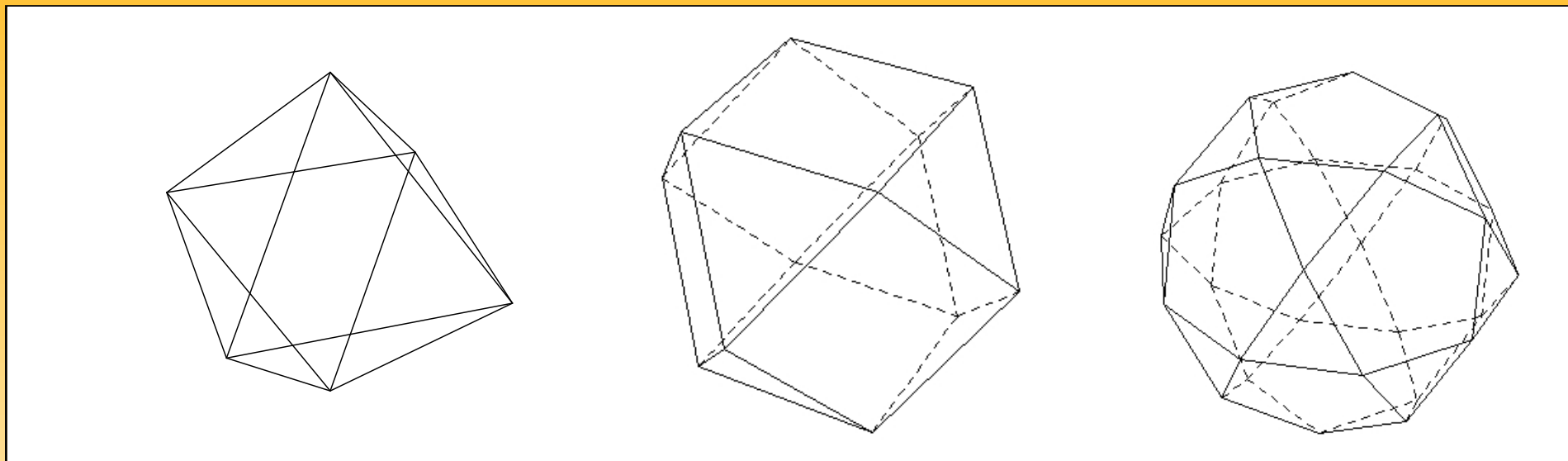

- octahedron, cuboctahedron, and icosidodecahedron share some properties, e.g. four nearest neighbors, classical ground state given by relative angle of  $120^\circ$  between neighboring spins;
- it might be possible to learn something about the icosidodecahedron by looking at properties of the smaller brothers;
- interesting questions: magnetization steps, frustration effects like intruders into the  $S = 0$ - $S = 1$  gap, rotational band structure.

# Outlook

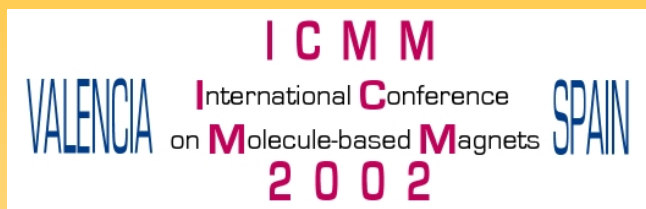

- magnetic molecules is a booming field:  
ICCM-2000: 200 participants,  
ICCM-2002: 425 participants;
- huge advances in coordination chemistry, it seems to be possible to synthesize “every” structure;
- dynamics plays a bigger and bigger role: relaxation, hysteresis, magneto-optical switching;
- interesting molecules have complicated couplings + anisotropy;
- molecules grow bigger and bigger  $\Rightarrow$  huge Hilbert spaces;
- systematics which connects structure and properties of observables highly required;
- interlinked structures of magnetic molecules are beyond nowadays computing - what to do?

# Thank you very much for your attention.

## Collaboration

- Prof. K. Bärwinkel, Prof. H.-J. Schmidt, M. Brüger, D. Mentrup, M. Exler, P. Hage, F. Hesmer, P. Shechelokovskyy (Uni Osnabrück);
- Prof. M. Luban, Prof. R. Modler, Dr. P. Kögerler, Dr. Chr. Schröder (Ames Lab, Iowa, USA);
- Prof. S. Blügel (FZ Jülich);
- Prof. J. Richter, J. Schulenburg (Uni Magdeburg);
- Dr. A. Honecker (Uni Braunschweig).

# Our group & Marshall Luban

